

FORCE TRANSDUCER WITH DIFFERENT CAPACITIES

Seif. M. Osman¹, R.Kumme², H. M. El-Hakeem¹, F. Löffler², Ebtisam H. Hasan¹,

R.M.Rashad³, F. Kouta³

¹National Institute for Standards (NIS), Giza, Egypt

²Physikalisch-Technische Bundesanstalt (PTB), Braunschweig, Germany

³Faculty of Engineering-Cairo University, Giza, Egypt

Abstract – Force transducers are usually used by national and accredited laboratories to calibrate force generated systems. Laboratories own several load cells to carry out calibrations, this forms an over cost for purchasing several load cells. One way to solve this problem is introducing a force transducer with different capacities. This article summarizes the achievements of proposing an economical force transducer with three different capacities works in compression mode.

Keywords: Force measurements, transducer, conceptual design, and proposed design.

1. INTRODUCTION

A force measurement system is made up of a transducer and associated instrumentation. The most common commercial force transducer is based on electrical principle (the load cell). The main part in the load cell is the elastic element on which a set of strain gauges are bonded to form the heart of the load cell which is the Wheatstone bridge circuit [1]. The main element stiffness is a governing factor in determining the load cell capacity (see equations (1) & (2)).

$$k = \frac{P}{\Delta L} \quad (1)$$

Where: k is the stiffness, P is the load and ΔL is the deformation

$$k = \frac{EA}{L} \quad (2)$$

Where: E is the modulus of elasticity, A is the cross-sectional area and L is the initial length

2. DIFFERENT-CAPACITIES LOAD CELL CONCEPT

The different-capacities load cell was introduced based on increasing the stiffness (k) for each range [3], increasing the stiffness require using harder elastic element.

Building a changeable-capacity load cell require different

values of stiffness, these different stiffness could be applicable through using a new elastic element for each range or combining more than one elastic element together for each range.

Using more than one elastic element -to change the capacity of the load cell- will directly reflect on the stiffness. Equation (3) shows the new stiffness (Ks) results from coupling elements in series, while equation (4) shows the stiffness (Kp) resulted from coupling elements in parallel [4].

$$\frac{1}{K_s} = \frac{1}{K_1} + \frac{1}{K_2} \quad (3)$$

$$K_p = K_3 + K_4 \quad (4)$$

Equations (3) and (4) show that adding elements in parallel increase the combined stiffness. During this work, the proposed designs were based on adding elastic elements in parallel.

1. CONCEPT FOR A LOAD CELL WITH THREE DIFFERENT CAPACITIES.

Manufacturing a load cell with three different capacities requires the ability to offer three values of stiffness, one for each capacity [5]. Simply for the load cell first capacity an elastic element nominated for the working range is loaded. For the second capacity a new introduced element is loaded instantaneously with the first element to withstand the load together (see fig. (1)). For the third capacity a another new introduced element is loaded instantaneously with the first and the second elements to withstand the load together.

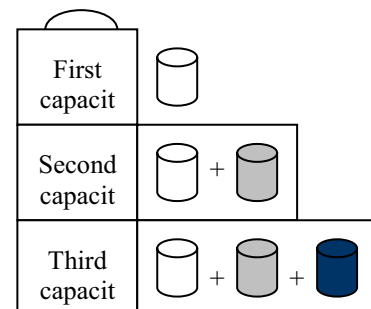

Fig.1. Schematic for a three range multi-capacity load cell elastic elements

4. PROPOSED DESIGNS

The proposed design is based on using concentric cylinders and a set of strain gauges bound on the main element forming a whetstone bridge circuit. The first and the second cylinders have protrusions (see fig.(2)). The load is applied using a universal rotating cap fixed to the load cell which is designed to rotate relatively to the load cell body. The universal cap has three pre-determined marks. Each mark is nominated for a range. There are also another three marks on the load cell body. Each is nominated also for a specific range. These marks indicate three positions: Position 1: for applying the load on the main element; Position 2: for applying the load on the main element and first cylinder; Position 3: for applying the load on the main element, first and second cylinders. The load cell capacity is determined by rotating the cap until the required capacity mark matches with the counterpart mark on the load cell body, which means that the right protrusions of both the cylinders and the cap face with each other.

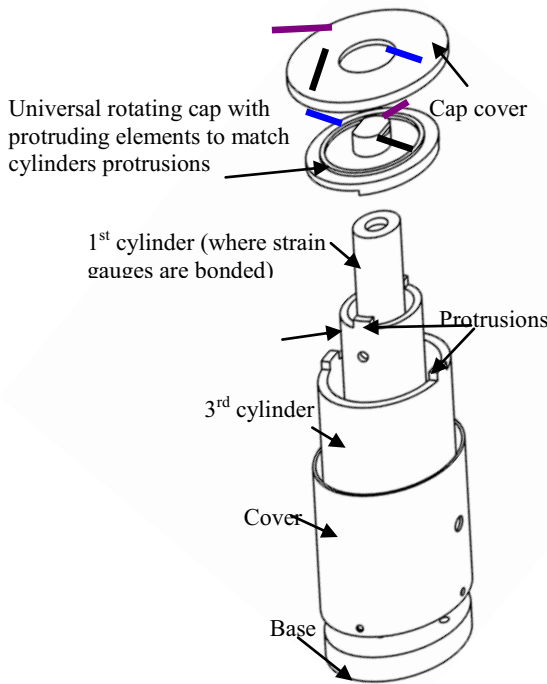
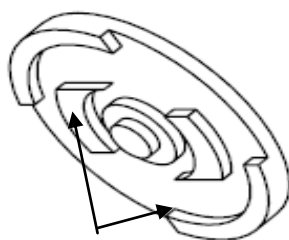

Fig.2. Proposal design

The rotating cap (see fig. (3)) has protrusions on its lower side. Also the cylinders have protrusions. As the protrusions are adjusted over each other, the load is distributed among the cylinders in contact with the rotating cap.



Protrusions

Fig.3. Universal rotating cap

5. PROTOTYPES

Different prototypes were manufactured and evaluated in NIS. The manufactured prototypes use concentric cylinders as additional elements to increase the stiffness to change the load cell capacity when required. Strain gauges are used to form a full Wheatstone bridge circuit on the main elastic element to respond to the force. One of the prototypes utilize two collars to close around the load cell loading point. The collars were fixed on the load cell cover to be integrated with a new recess in the cap (see fig. (4)).



First prototype

Second prototype

Fig.4. Preliminary prototypes

The preliminary checks carried out on the manufactured prototypes show that the range selection mechanism is satisfactory and works successfully but the results reveal some criticism which was taken into consideration during developing the design in PTB in order to manufacture an accurate and precise different capacities load cell.

6. FINAL PROTOTYPE

The final prototype was proposed after developments. It is characterized by some new features related to the design and reflected on the load cell dimensions and weigh to manufacture a comparative load cell. Based on PTB past experience [6], the four main parts were manufactured from DIN1.6580 (30CrNiMo8, $\sigma_y \approx 1000$ MPa), while DIN 1.4301 (X5CrNi18-10, $\sigma_y \approx 190$ MPa) was used to manufacture the rest of the load cell as it has good corrosion resistance.

A comprehensive stress analysis using finite Element Analysis Program (Abaqus FE program version 6.5-1) was carried out to develop, optimize and check the efficiency of adding elements.

A test load of 15kN was used to verify the effect of adding element in parallel. Three models were evaluated and each model simulates one capacity of the three capacities.

Results show that the stress on the main element (first range) decreases by adding the new element (first cylinder-second range) from the hypothetical value 164 Mpa to 115.5 Mpa (i.e. 30% decrease) and after adding the newer element (the second cylinder-third range) decreases more to be 100 Mpa (i.e. 40% decrease) with a difference equal to 64 Mpa from the first range. (See fig. (6)).

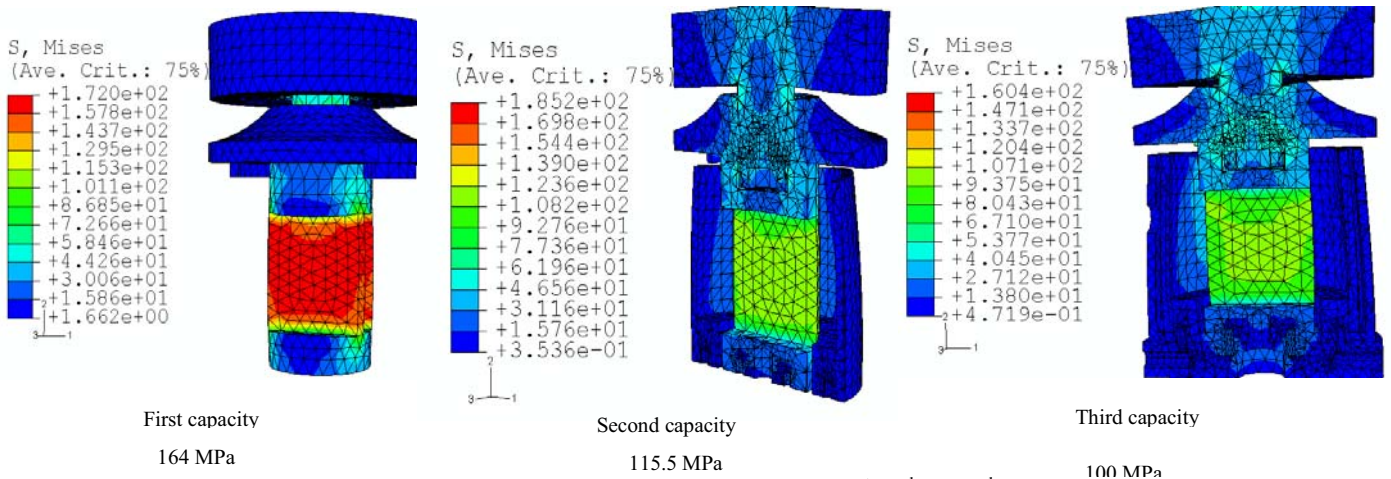

Fig.5. Results of FE stress due to 15kN load on 1st, 2nd and 3rd ranges

7. MANUFACTURING

Low tolerances (approximated 10 μm flatness) were required at the top of the main parts assembly (see fig (7)). This is to ensure that the main element and the protrusions are on the same plane. This machining tolerance was achieved by a grinding process. Grinding is the final machining process that was applied to the top surface of the main parts assembly after the strain gauges were adhered to the main element and protected.

The machining process was carried out in PTB's Scientific Instrumentation Department which is equipped by high accurate machines.

Two bi-axial strain gauges 1-XG11-3/350 manufactured by HBM co. with a 3 mm gauge length and a 350 ohm gauge resistance were adhered on the main element (one on each side) to form the Wheatstone circuit [7]. (see fig.(8)). This schematic diagram plans the application process and shows the positions for strain gauges, connecting terminals, connecting wires and extension wires. Figure (8) also shows terminals of a 15-pin D-sup plug which was used to connect the bride to the strain indicator.

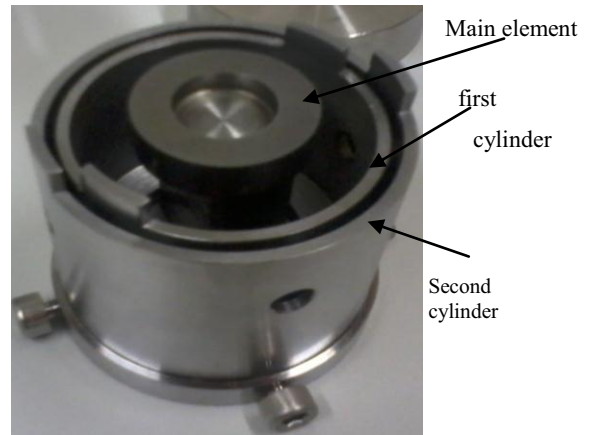

Fig.6. Main parts assembly

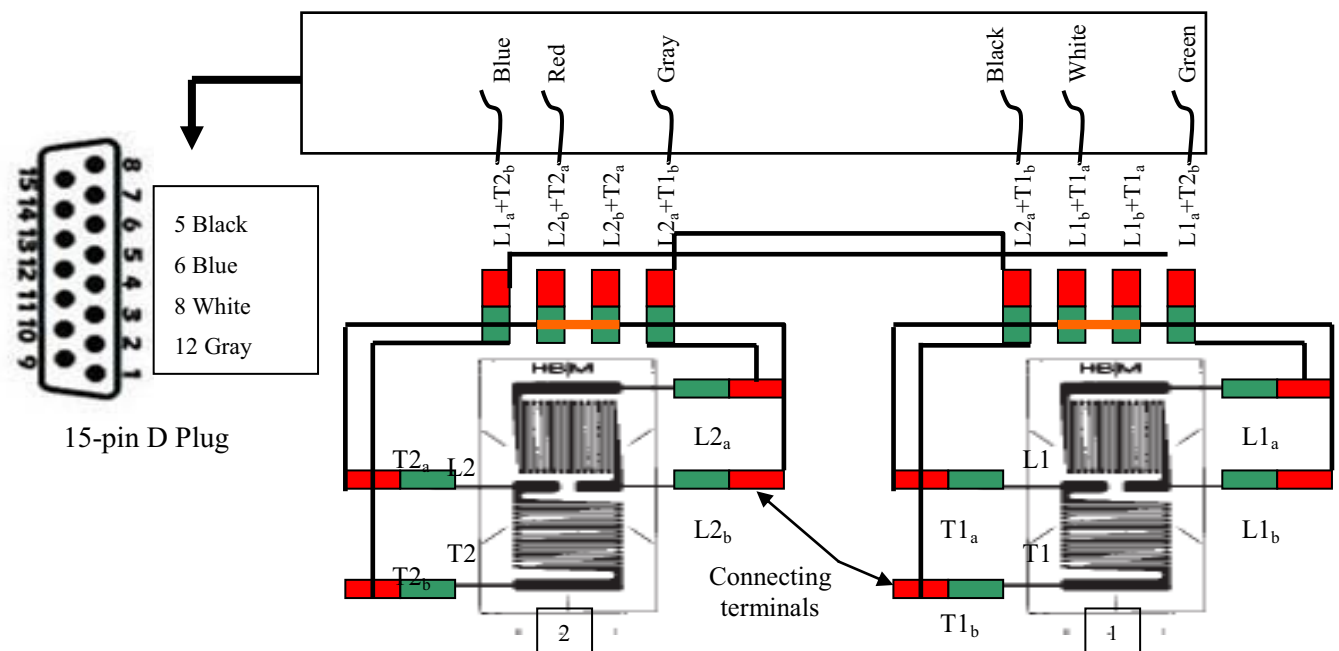

Fig. 7. Schematic wiring for strain gauges, terminals and connecting wires

8. MEASUREMENTS

Check measurements were carried out on the manufactured load cell using PTB 20kN deadweight machine. Measurements aim to practically compare the effect of adding elements. Two loads (3kN & 5kN) were applied on the three ranges. Table (1) shows the response of the manufactured transducer under the loads. Values prove the efficiency of adding elements to increase the stiffness.

Table 1. Response under loads.

Load kN	Response (mV/V)		
	First range	Second range	Third range
3	0.221479	0.135401	0.103403
5	0.363655	0.232232	0.185130

9. CONCLUSION

This article shows the progress of introducing force transducer with different capacities works in compression mode. Different prototypes were manufactured with a design concept based on increasing the stiffness of the sensing element. The final proposed prototype was designed, checked by finite element techniques and manufactured to cover three different capacities (5kN, 10kN and 15kN) (see fig. (8)). Machining process show the need of accurate machining techniques in order to achieve the required tolerances.



Fig. 8. Manufactured multi-capacity load cell without loading plate

10. FUTURE WORK

The manufactured multi-capacity load cell will be calibrated according to the international standard ISO 376-11 to investigate its metrological characteristics [8]. Also it would be more valuable to apply this concept in manufacturing a multi-capacity load cell with a range difference increase by the power of ten (example: 5 kN, 50 kN and 500 kN).

REFERENCES

- [1] Dan Mihai Stefanescu, Alexandru Stefanescu."Criteria for Choosing the Elastic Elements of Force Transducers" Proceedings of the 17th International conference IMEKO, pp. 134-140, Istanbul, Turkey, Sept.2006.
- [2] M.-S. Kim*, Y.-K. Park and J.-H. Kim, "Millimeter-Scale Piezoresistive Cantilevers for Accurate Force Measurements at the Nano-Newton Level" MAPAN-Journal of Metrology Society of India (December 2013) 28(4):251–257
- [3] Seif. M. Osman, Ebtisam H. Hasan, H. M. El-Hakeem, R. M. Rashad, F. Kouta "Conceptual Design of Multi-Capacity Load Cell" Proceedings of 16th International Congress of Metrology 7-10 October 2013 Paris, France.
- [4] Shigley's Mechanical Engineering Design," Mechanical engineering", McGraw-Hill, Eighth edition 2006, ISBN:0-390-76487-6.
- [5] Seif. M. Osman, Ebtisam H. Hasan, H. M. El-Hakeem, R. M. Rashad, F. Kouta "Multi-Capacity Load Cell Concept" Sensors & Transducers journal, Vol.178-179, Issue 9, pp.229-233, September 2014.
- [6] F.Tegtmeier, M. Peters "Multicomponent Sensor for Stress Analysis in Buildings" Proceedings of the International Conference of IMEKO, Germany, Sept. 2002.
- [7] HBM catalogue "Strain gauges and accessories" www.hbm.com.
- [8] International Standard ISO376:2011 "Metallic materials – Calibration of force-proving instruments used for the verification of uniaxial testing machines" Fourth edition, June 2011.